

History and role of CPT: Equipment and Procedures



CPT /CPTU

What is a CPT/CPTU and what do we measure?

Historical overview

Equipments for testing

Deployment systems

Onshore

Offshore

Various CPT/CPTU equipments available

Data acquisition

NGI

Principle of testing with CPTU

Cone rig with hydraulic pushing system

Cone Penetration Test (CPT)

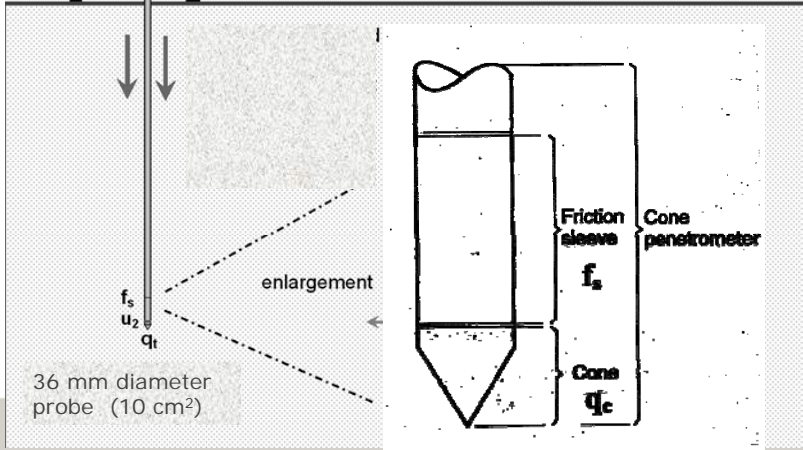

TERMINOLOGY FOR CPTU AND WHAT DO WE MEASURE

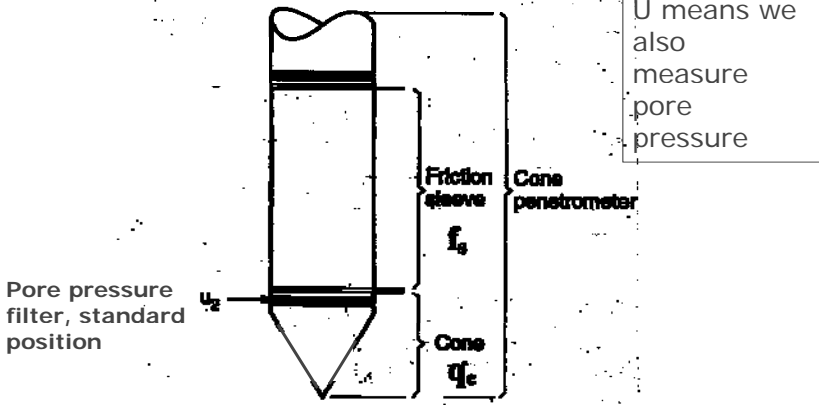

In addition frequently measure inclination, i

Traditional approach by CPTU

Range of cone penetrometers available

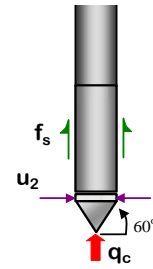
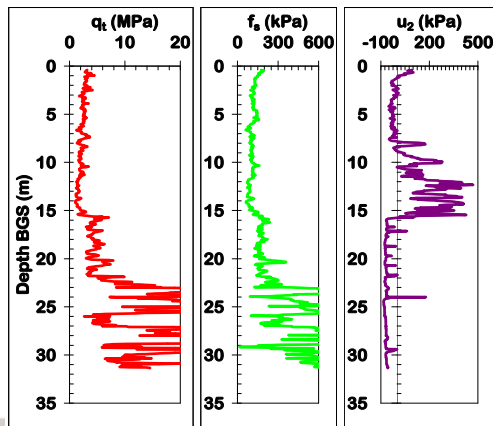

Typical CPTU result

Example CPTU profile

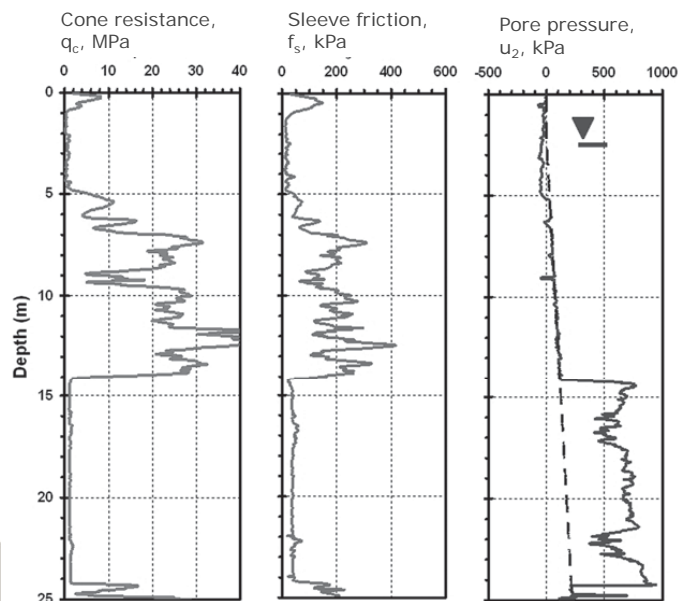

HISTORICAL BACKGROUND CPT

1932 First Dutch cone penetration tests (by hand)

1935 Delft Soil Mechanics Laboratory (DSML) performs CPT with 10 t manually operated rig

1948 Improved design of Dutch cone including conical mantle

1953 Measurement of friction sleeve added to mechanical cone

1948 DSML develops first electrical cone

1965 Fugro develops electrical friction cone

INGI

THE FUGRO ELECTRICAL FRICTION CONE (AFTER DE RUITER, 1971)

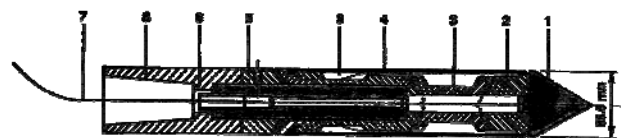

- | | |
|-----------------------|------------------------|
| 1 Central rod (10 cm) | 5 Adjustment ring |
| 2 Load cell | 6 Waterproof housing |
| 3 Strain gauges | 7 Collar |
| 4 Friction sleeve | 8 Connection with rods |

INGI

Example combined CPT and pore pressure probe Piezocone or CPTU

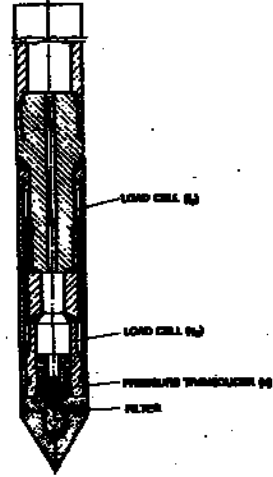

First used 1980

The Inverse Piezocone

Examples measured CPTU parameters

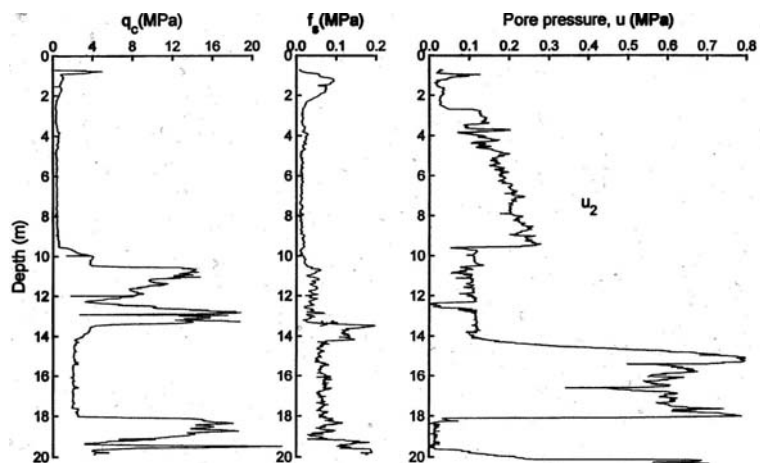

Example: Measured CPTU Parameters

Deployment of CPT/CPTU

Equipment now exists for pushing in cone penetrometers into soil for a large range of conditions

- on land
- offshore

NGI

Example CPT rigs



Geomil rig



Geotech simple rig

NGI

CPT/CPTU on land



Modern truck mounted system *(ConeTec/Gregg)*

CPT/CPTU on land



Track-mounted system

(ConeTec/Gregg)

Standard CPT Rigs

LANKELMA
CONE PENETRATION TESTING LTD.

20 Tonne Crawler



NGI

Non-Standard CPT Rigs **LANKELMA** CONE PENETRATION TESTING LTD.

19 Tonne Special Rail truck

Rapid investigative technique. Minimal set-up and test time per location. No reinstatement required

Optimises track possession time more effectively

Mini-crawler with inclined rams for rail embankments

No lifting required for mobilisation



Non-Standard CPT Rigs **LANKELMA** CONE PENETRATION TESTING LTD.

1.5 Tonne Mini Crawler

Suitable for restricted access (rubber tracked, low ground bearing pressure)

Thrust capacity 20 tonnes

Reaction weight 1.5 tonnes (increased with ground anchors & water tanks)

Suitable for Railway related work



Pagani small trackmounted CPT rig



NGI

Versatile Mobile Rams

LANKELMA
CONE PENETRATION TESTING LTD.

Embankment CPT's



NGI

CPT/CPTU on land



Drill-rig
system

(ConeTec)



Low
headroom
CPT -
Inside
buildings

(ConeTec/Gregg)

CPT in London Underground tunnel



Courtesy of Lankelma, UK



Coson[®] 200 kN

Continuous Static cone penetrometer

Take-over principle

Time saving about 7 sec/m

No loss of data at one meter intervals

No dissipation effects interfering with pore water pressure measurements.





Schematic overview of Autocoson system

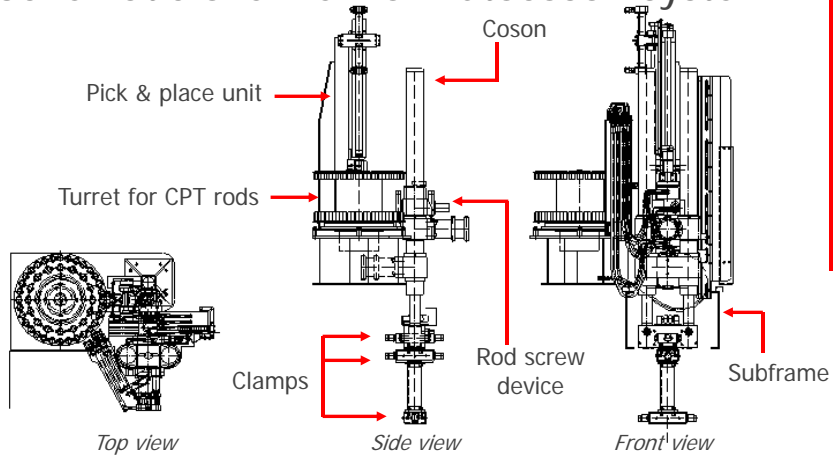

Robotic operation

TOTAL CONE PUSH FORCES WITH AND WITHOUT MUD INJECTION (FROM JEFFERIES AND FUNEGÅRD, 1983)

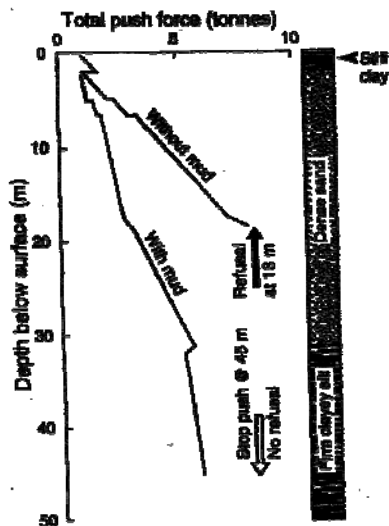

Example of increasing penetration

In situ testing in offshore geotechnical investigations

Deployment platforms

Jack up rigs

Barges

Survey ships

Special soil drilling vessels

NGI

Investigations from jack-up platform



Use casing and landbased equipment

NGI

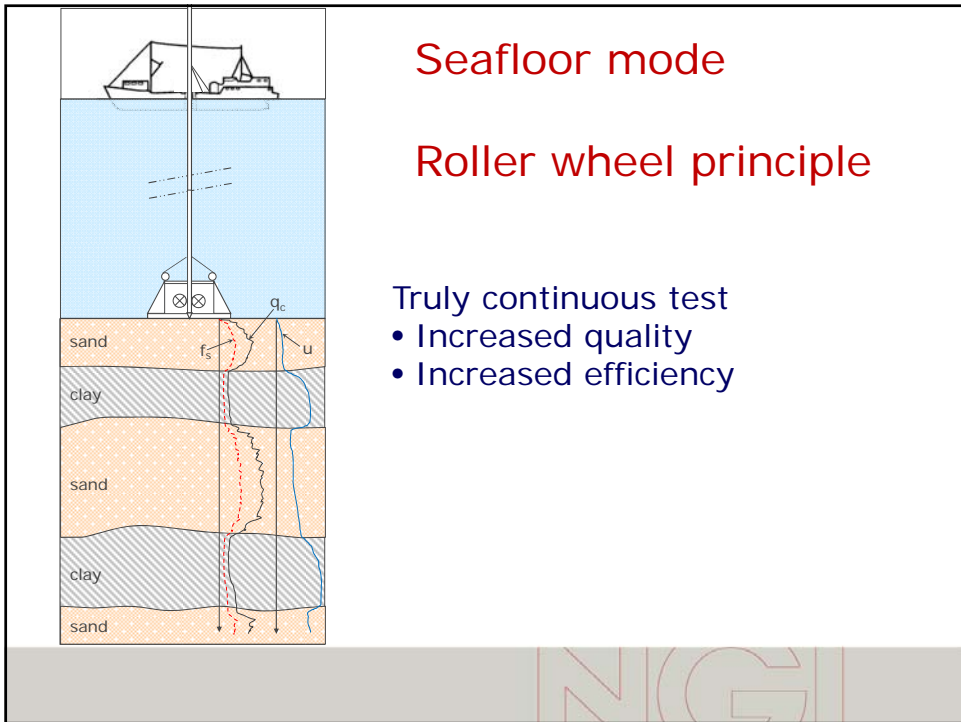
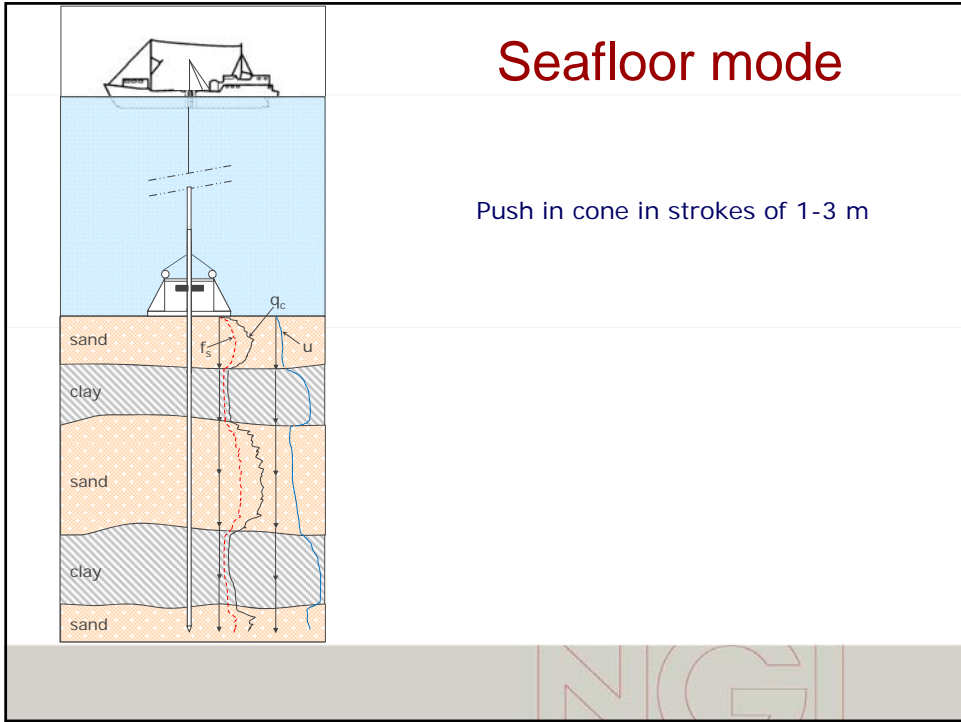

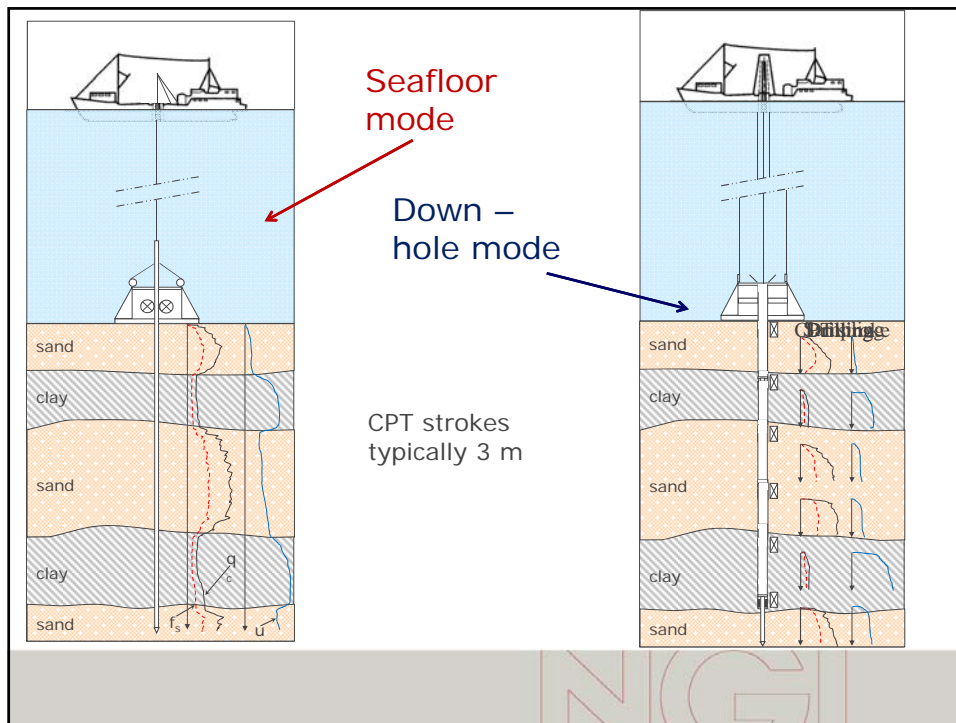

In situ testing in offshore geotechnical investigations

Basically two modes of operation:

- **Seafloor mode**
- **Down-hole mode**

In situ testing in offshore geotechnical investigations

Sea bottom rigs:

Standard size rigs (e.g. 10 or 15 cm² cone penetrometers)

Minirigs (1 to 10 cm² cone penetrometers)

NGI

Fugro's wheeldrive CPT system

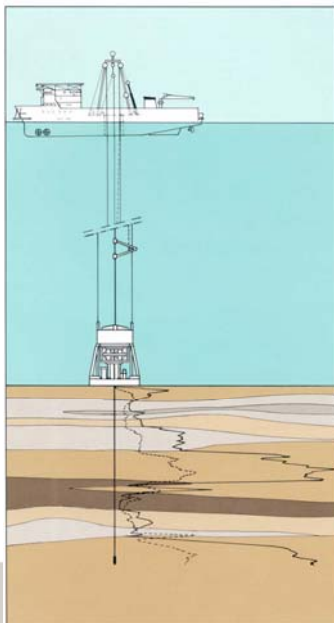

Heavy duty
rig 20 t,
profiling to
45-50 m
penetration
possible

From brochure

NGI

Example of light mini-rig for use in deep waters - Neptun



Datem,
UK

Example of light mini-rig for use in deep waters

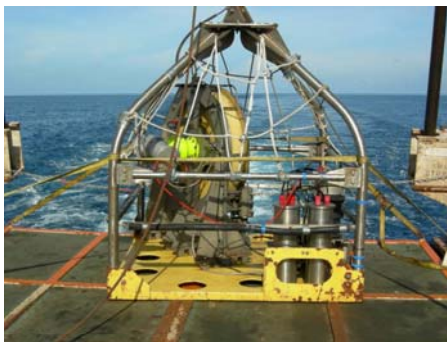

Neptun 2 rated for 15 m penetration, can use 10 cm² or 5 cm² cone

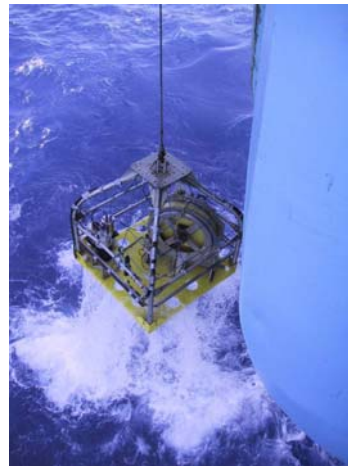

Courtesy of Gardline Geosciences

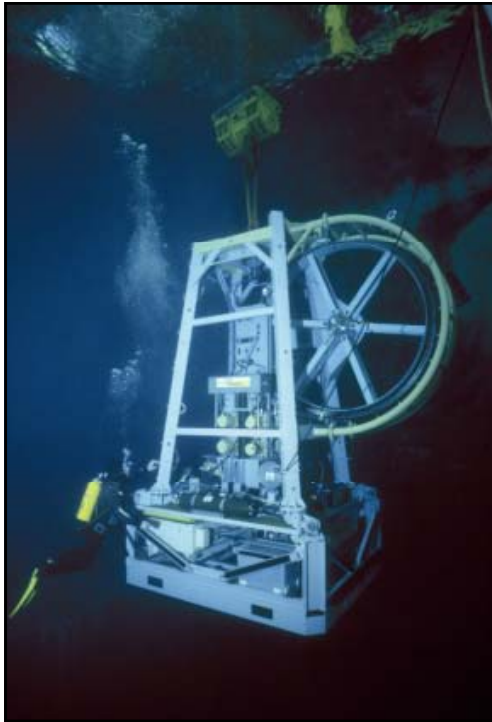

PENFIELD developed by IFREMER, France, 2000

Specifications:

- Water depth: 6000 m
- Penetration force: 40 kN
- Push rods 36 mm dia
- Drive belt and rod straightner
- 30 m penetration
- Rods can be used 100 times
- Drum diameter = 2.15 m

htner
g
raulic
ors
©
s



Geo's combined CPT and Vibrocore seabed rig "GeoCeptor"

CPT and vibrocore in "one operation"

CPT up to 10 m depth

Soil sampling up to 6 m depth

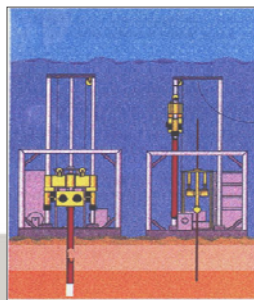

GEO “CPT-ROV”

Weight: 200kg
Deployment depth: 3000m
Max penetration: 3 m
Cone dimensions:
10cm² 5cm²



Down-hole insitu testing

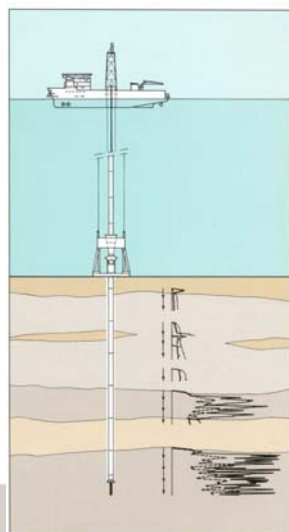

Principle with drilling unit on ship, usually:

Operation with umbilical, hydraulic cylinder pushes tool below bottom of borehole. Data acquisition through cable and real time display of test results. Depth limitation about 700 m.

From Fugro brochure

APvandenBerg's WisonAPB from 1973



Limitation at about 600- 700 m depth due to weight of umbilical

Derrick w/powerswivel and drill string

Downhole deployment tool

umbilical

Cable for mechanical strength, electrical signals and hydraulic oil

Courtesy of Gardline

NGI

Down-hole insitu testing

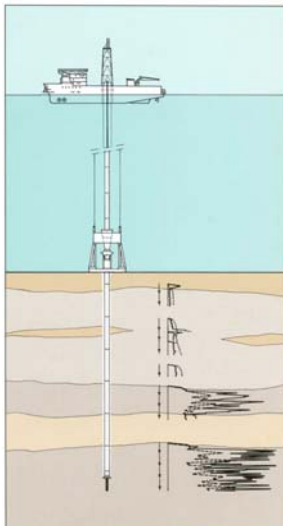

Principle with drilling unit on ship, alternatives for deeper waters:

Use mudpressure to push CPT into soil from bottom of borehole. CPT data stored in memory unit and recovered when tool is brought back to deck.

NGI

Downhole mud pressure and memory system

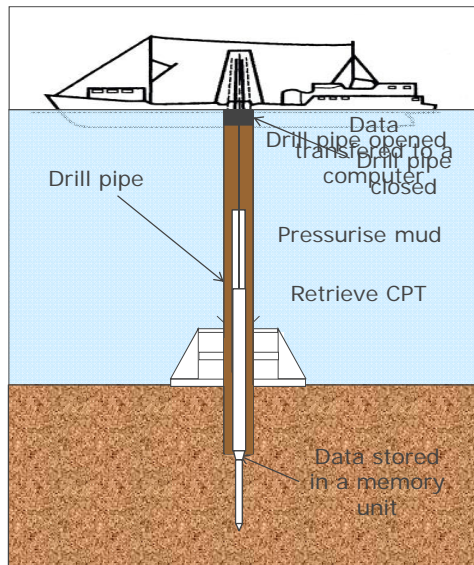

Down-hole insitu testing

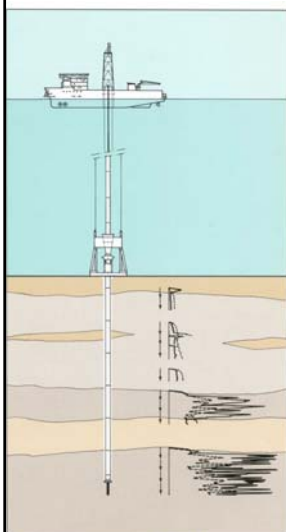

Problem with mud pressure and memory unit: do not know if test is successful before tool is back on deck

Newly developed deep water Wilson-APB.
Electromechanic cable, no hydraulics.
Can be used in water depths up to 3000m.

Real time data are obtained

Seabed or down-hole testing ?

Advantages of seabed testing:

Easier and quicker deployment

Less expensive ships can be used

Higher quality of tests due to no soil disturbance due to drilling

NGI

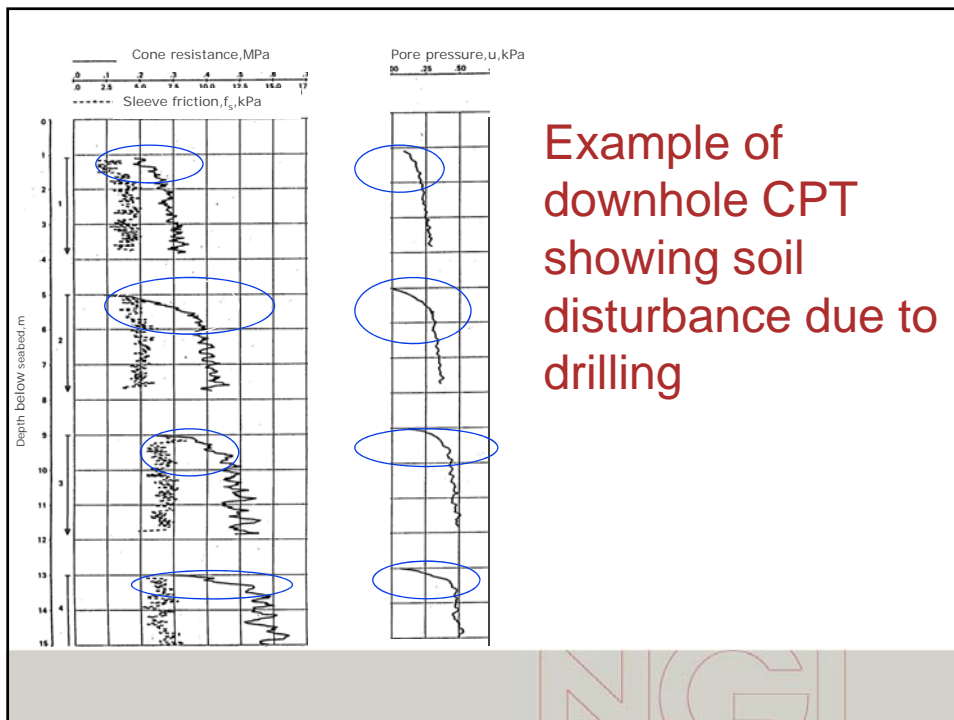

NGI

Example of downhole CPTU showing little drilling disturbance

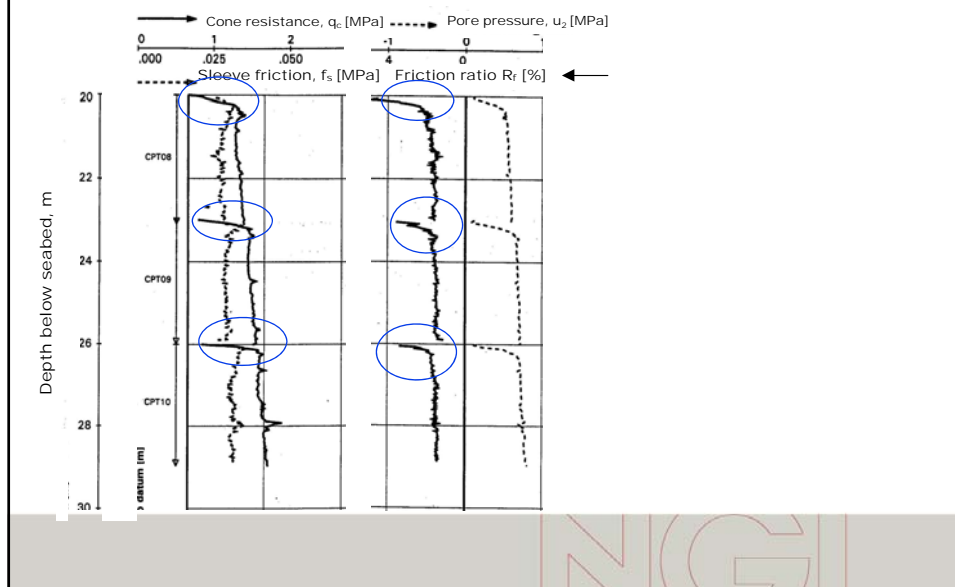

Seabed or down-hole testing ?

Advantages of down-hole testing:

- **Penetrations to 150 m or more**
- **Hard layers can be penetrated**
- **Possible to do combination of different types of in situ tests and/or sampling**

Seafloor based drill rigs

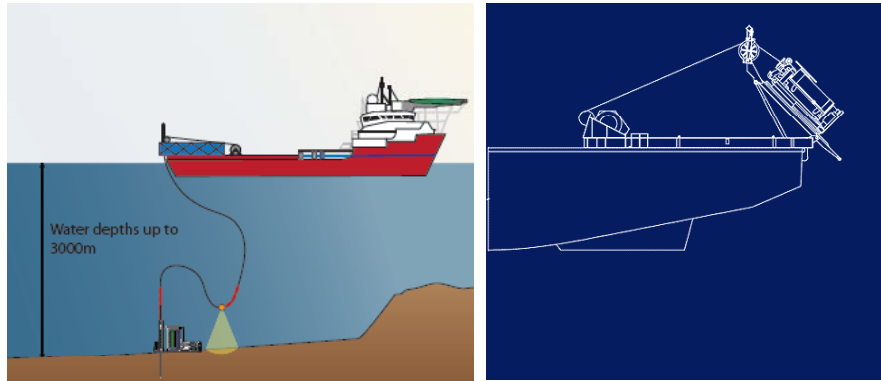

Portable Remotely Operated Drill (PROD)

Operated by Benthic, Australia

PROD : Horizontal Launch & Recovery



Courtesy of Benthic Australia





Benthic's PROD

Advantages of seafloor based drill rigs:

- Accurate depth control/measurements
- Accurate zeroing of CPT sensors for Down-hole testing
- Better quality CPTU data compared to vessel based drilling
- Increased efficiency: depends on circumstances

Gregg's Seafloor Drill

Depth rating: 4,000 msw [13,120 fsw]

Weight in air (approx): 9,100 Kg
[20,000 lbs.]

System dimensions

Width: 3.8 m [12' 5.6"]

Length: 5.4 m [17' 8.6"]

Height: 6.6 m [21' 7.8"]



Seafloor Drill

Drilling specification

Rotary Speed - 0-500 (both directions)

Drill Rods – Diamond tip, 2m length tooling

Maximum drill depth and core retrieval: 150m

Cores: N series up to P series tools, wire line retrieval

Working deck area drill spread of 70m²

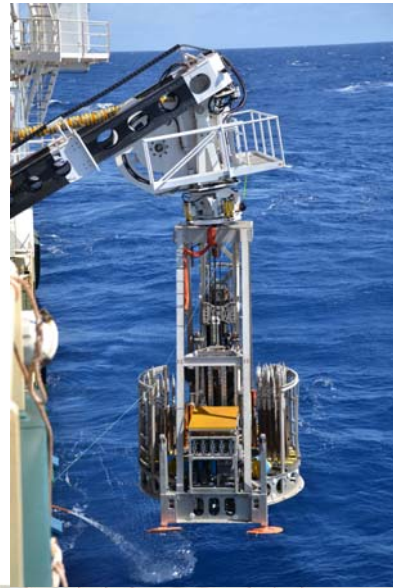

53

Seafloor based drilling and CPTU sampling

This technique is proving to be very efficient (especially in deep waters) and give better quality CPTU data compared to vessel based drilling

In addition to Benthic other systems have been developed and are entering the market

Gregg Drilling in partnership with Fugro world wide

ROV Drill operated by Canyon Offshore in cooperation with Gardline, UK and world wide

MEBO drill operated by MARUM, Germany

CPT/CPTU MEASUREMENT SYSTEM

Depth measurement

Cone resistance/sleeve friction strain gauge load cells

Pore pressure - pressure sensors

Data acquisition

INGIL

CPT/CPTU MEASUREMENT SYSTEM

Depth measurement

INGIL

EXAMPLE OF DEPTH REGISTRATION SYSTEM

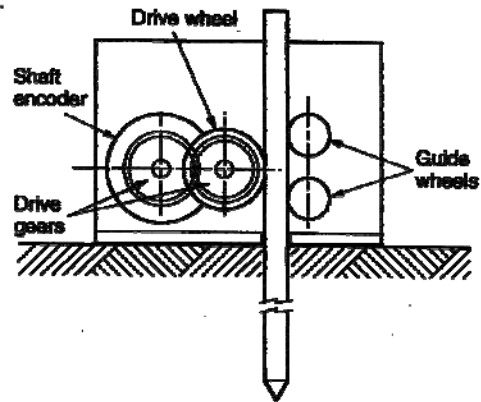

EXAMPLE OF DEPTH REGISTRATION SYSTEM

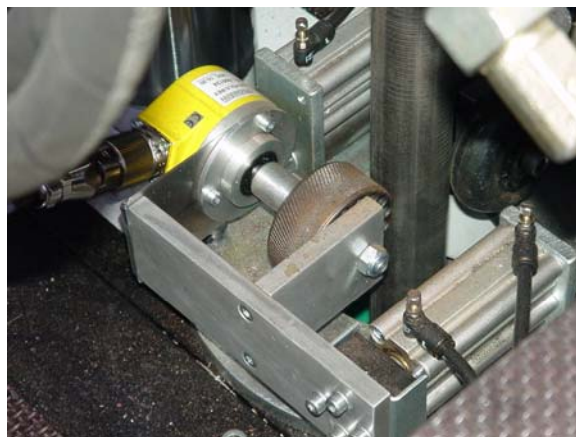

Courtesy of APvandenBerg

CPT/CPTU MEASUREMENT SYSTEM

Depth measurement

Cone resistance/sleeve friction strain gauge load cells

Pore pressure - pressure sensors

NINGJI

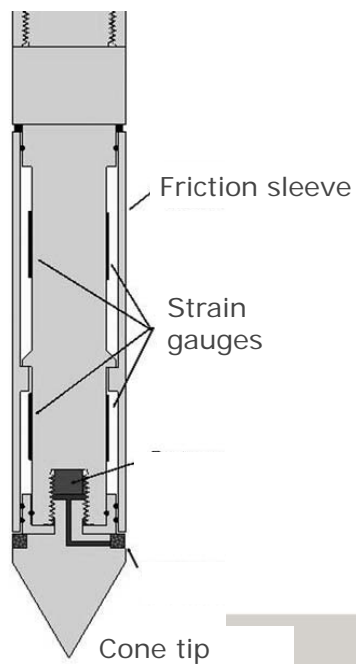

DESIGN OF CONE PENETROMETERS.

CONE RESISTANCE AND SLEEVE FRICTION LOAD CELLS IN COMPRESSION

NINGJI

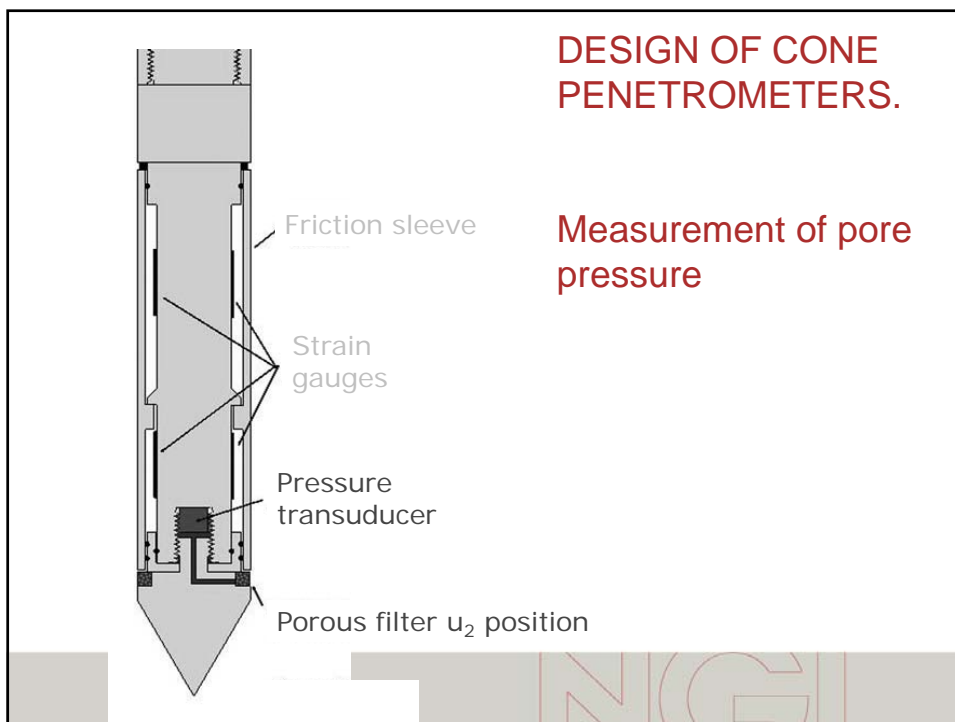
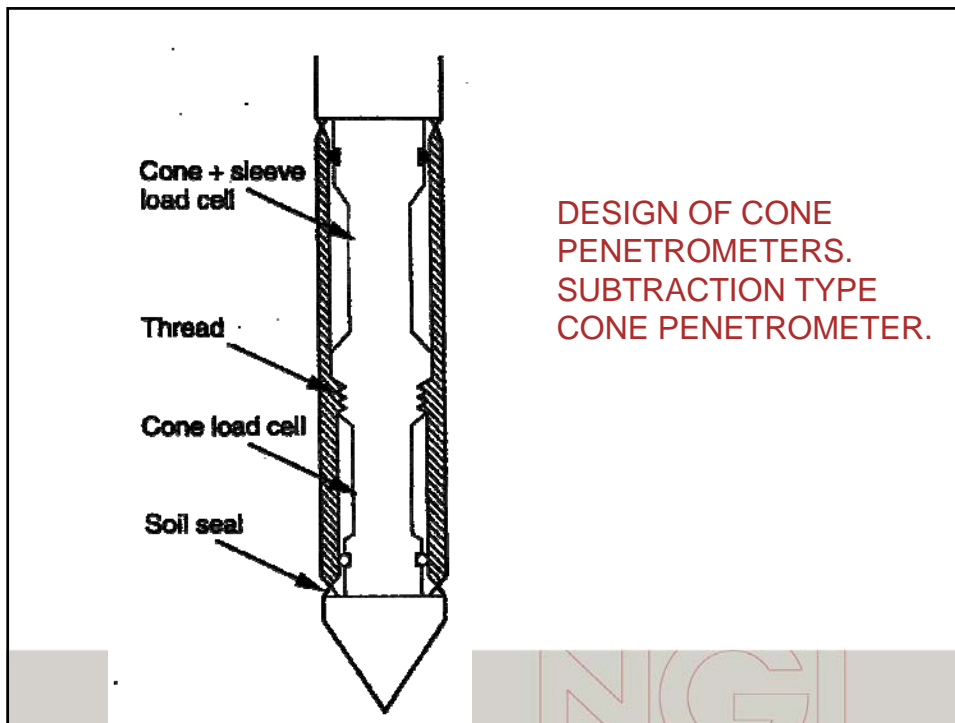

CPT/CPTU MEASUREMENT SYSTEM

Depth measurement

Cone resistance/sleeve friction strain gauge load cells

Pore pressure - pressure sensors

Data acquisition

Transmission via cable

Acoustic transmission

Storing data in memory mode

NGI

CPT/CPTU MEASUREMENT SYSTEM



Traditional approach using cable

NGI

GEOTECH'S SYSTEM WITH ACOUSTIC TRANSMISSION OF SIGNALS

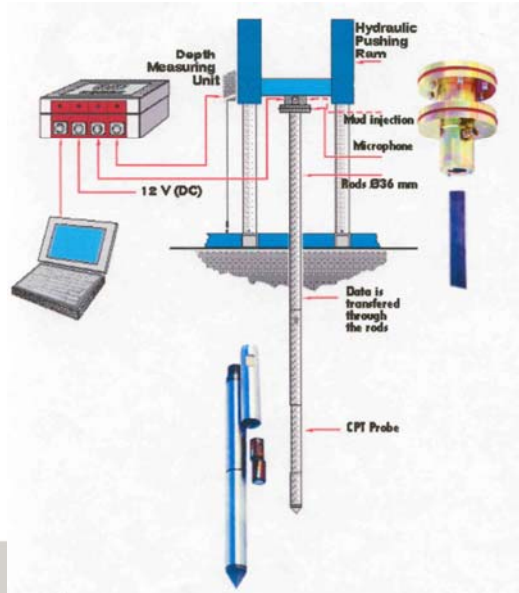

GEOTECH'S SYSTEM WITH ACOUSTIC TRANSMISSION OF SIGNALS

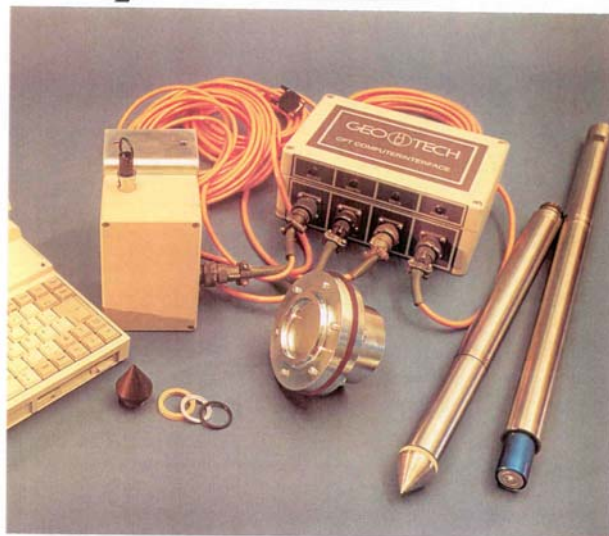

Geotech's wireless CPT-system,
a different solution

RW NOVA

This is the newest and most efficient way to do CPT. The radio waves carries the CPT measurements inside the rods, up in the air and to the receiver. Note that the receiver does not need to be in contact with the end of the rod. It can be mounted one meter above the end of the rod and still receive the signal. RW NOVA gives future possibilities to do cordless SCPT, down hole video camera and other data consuming sensors.

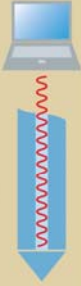

ACOUSTIC NOVA

Similar to CPT GEOTECH CLASSIC. The acoustic signal carries the CPT measurements through the steel in the rods to a microphone. The microphone is used to push the rods and at the same time receiving the signal. This popular system makes the CPT easy to perform. Acoustic NOVA can also be used in water. To reduce skin friction on the rods they can be lubricated with bentonite while pushing and the bore hole can be sealed with bentonite or similar when retrieving the rods.



GEOTECH'S FLEXIBLE SYSTEMS

CABLE NOVA

This is a normal Cable CPT system. The system can easily be upgraded to ACOUSTIC NOVA or RW NOVA.



MEMORY NOVA

When using the memory system no signal needs to be sent to the surface. Simply make the sounding, and use the memory read-out unit to connect to a computer and transfer all data. Surprisingly simple to use.





Schematic overview Optocone® System

Data acquisition system

LED driver adapter to send commands to the Optocone

Camera

CPT string

CPT rod with Light conductor and special quick connect thread

Battery pack (power supply for optocone electronics)

Optocone electronics (Signal conditioning and A/D conversion)

Standard Cone (q_c , f_s , U , I_x and I_y)

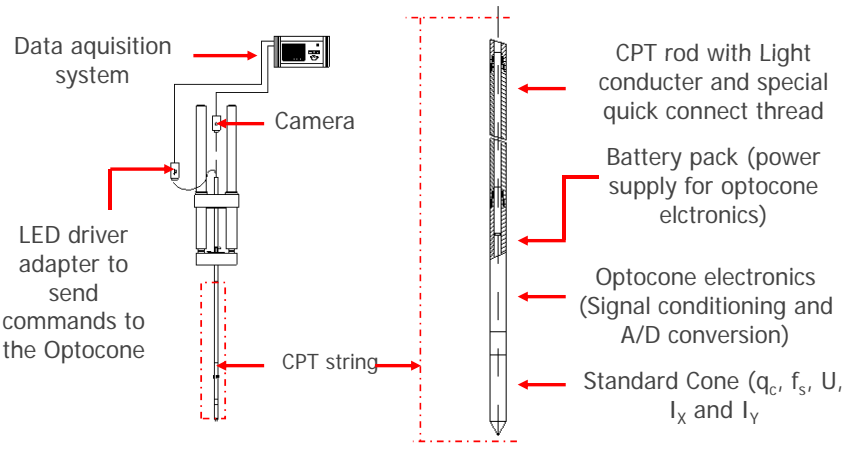

ProductInfo

Envi™ Memocone II CPT Probe

- Flexible - cordless or with cable
- Measuring point resistance, local sleeve friction and pore pressure
- Easy storage of data
- Easy calibration of probe
- Fulfills highest ISSMFE class
- Used world-wide



Envi Memocone II

ProductInfo

Envi™ Geoprinter 60 Drilling parameters, CPT data collector and printer 22 channels

Programmable for a number of methods:

- CPTu sounding
- Tunnel grout hole probing
- Jet grouting
- Percussive drilling
- Penetration testing
- Diamond core drilling
- SPT Sounding
- Dynamic Testing DIN
- Quality Control of Lime Columns
- Ram sounding

Weather proof instrument

Easy to install on all drills

Easy to adapt to all methods



Envi Geoprinter 60

History, Equipment etc

Over last 50 years CPT/CPTU has developed into very efficient technology

We now have very well developed equipment for testing onshore, nearshore, offshore

NGI

TERMINOLOGY FOR CPTU AND WHAT DO WE MEASURE

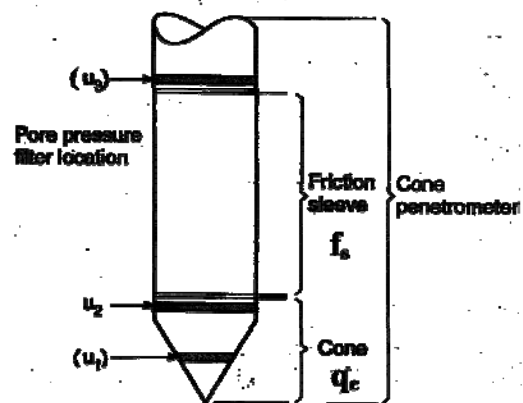

In addition frequently measure inclination, i

NGI